

ZenBox Lockers

Aluminium and SGL lockers for wet area environments



Probe

ZenBox lockers

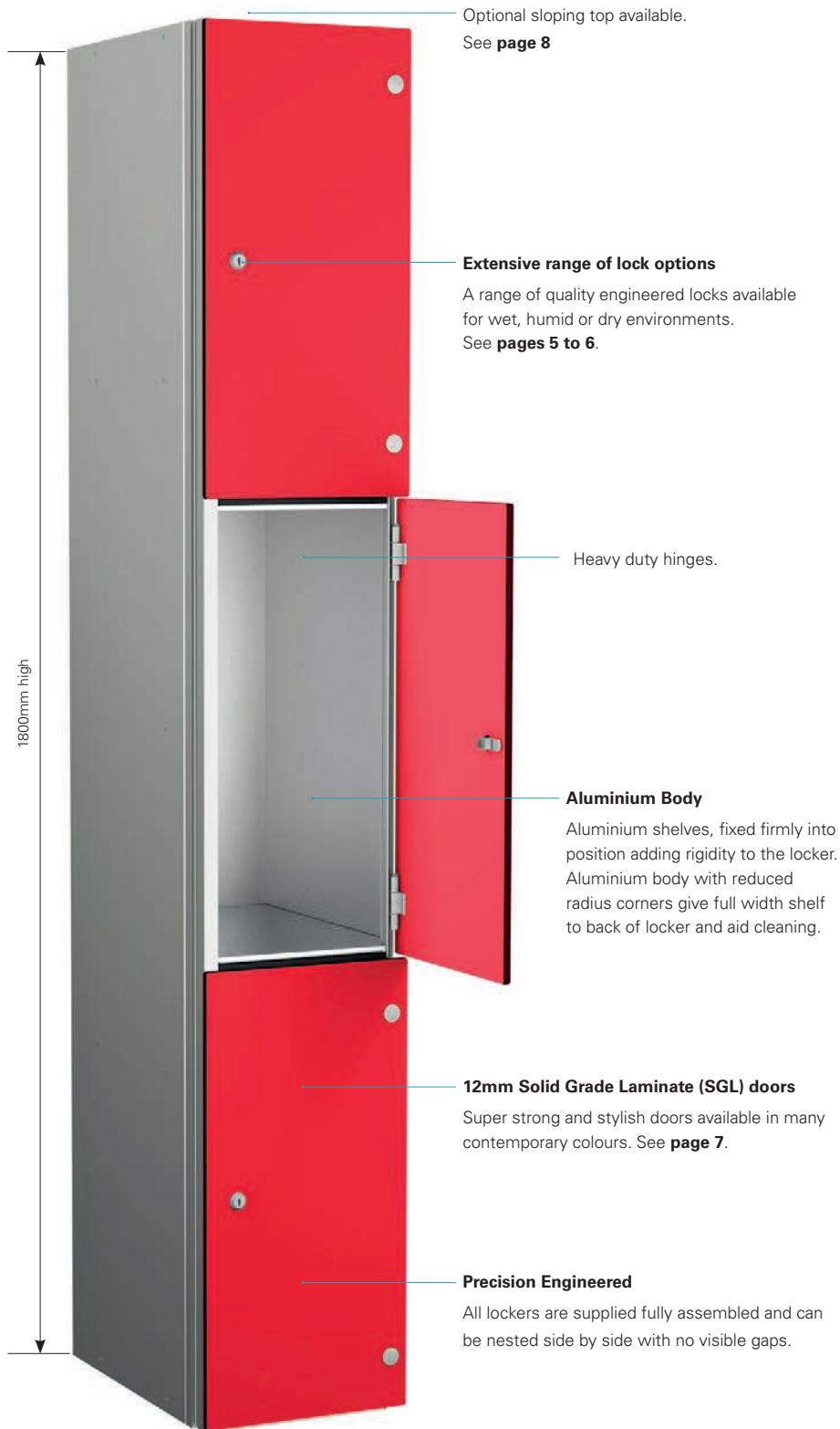

Optional sloping top available.
See **page 8**

Extensive range of lock options

A range of quality engineered locks available for wet, humid or dry environments.
See **pages 5 to 6**.

Heavy duty hinges.

Aluminium Body

Aluminium shelves, fixed firmly into position adding rigidity to the locker. Aluminium body with reduced radius corners give full width shelf to back of locker and aid cleaning.

12mm Solid Grade Laminate (SGL) doors

Super strong and stylish doors available in many contemporary colours. See **page 7**.

Precision Engineered

All lockers are supplied fully assembled and can be nested side by side with no visible gaps.

Designed and engineered ZENBOX lockers are the perfect choice for demanding environments.

ZENBOX lockers are designed and engineered to withstand the rigours of high use wet area environments where the requirements of design with durability and image are paramount.

- Leisure Centres
- Swimming Pools
- Schools
- Gyms
- Spas



Important note regarding locker installations

Wherever possible lockers should be secured to ensure stability. Single lockers should ideally be fixed back to a wall. Runs of lockers should be fixed together side-to-side and either fixed back to a wall or fixed back-to-back to another run of lockers.

ZenBox locker range



End panels to match doors

End panels can be manufactured to add on to the end of locker runs or to the side of each individual locker if required.

1800mm high

Single compartment

Fixed top shelf with double coat hook.

Two compartment

Double coat hook per compartment.

Three compartment

Four compartment

Six compartment

Height - 1800mm*	
Width mm	Depth mm
300	450
300	500
400	450

* Height rises by 150mm with sloping top

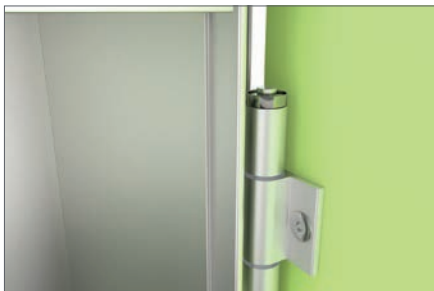

Heavy duty self-closing hinges engineered to prevent the doors opening across adjacent compartment.

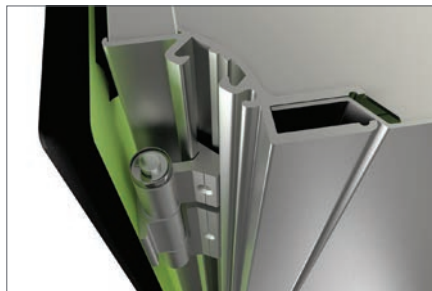

Concealed hinge within extruded aluminium frames engineered for added strength and stability.

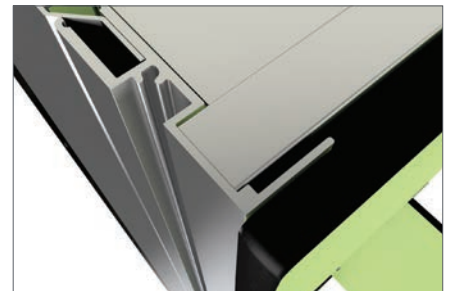

Flush frame for zero gap when lockers are nested.

ZenBox Ultra outdoor lockers



Sloping top

ZenBox Ultra lockers feature sloping tops to aid water dispersion.

Height - 1800mm*	
Width mm	Depth mm
300	450
300	500
400	450

Available in 1, 2, 3, 4 and 6 compartments



Integral door seal

This seal ensures there is no water ingress into the locker compartment.



Important note regarding locker installations

Wherever possible lockers should be secured to ensure stability. Single lockers should ideally be fixed back to a wall. Runs of lockers should be fixed together side-to-side and either fixed back to a wall or fixed back-to-back to another run of lockers.

Wet area lock options



Type 3 Probe cam lock*

Even the standard lock has a micro sprung 10 disc lock featuring a massive 3000 serial combinations- all exclusive to Probe. Two keys are included with each standard lock.



Type 2 Hasp and staple*

Attractive design allowing easy use of padlock fitting. Shank diameter maximum 7mm and minimum 5mm
Padlock sold separately.

Replacement hasp & staple

This Hasp & Staple is available to purchase separately if you need to change your existing lock.



Type 11 Re-programmable combination lock

User re-programmable.
An effective 4 digit code combination lock with 10,000 possible combinations, making losing keys a thing of the past.
NOT Suitable for multi user applications. Master override key sold separately.

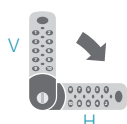

Type 6 Digital combination lock 40,000 combinations

Simple to program battery operated lock which can last up to 50,000 operations before needing changing. Emergency access using service key. Single user supplied as standard but multi-user option is available (specify when ordering)**Can be used vertically**

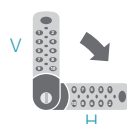

Type 10 The RFID keyless digital combination lock

This lock provides contact less RFID locking and can be used independently or paired with existing wireless systems. Simple to upgrade existing installations and compatible with most wireless standards including RFID and NFC, the lock comes with a wide range of accessories and options.



Type 8 Waterproof coin/token Return/Retain

These Waterproof and Chlorine resistant locks are available with coin denominations £/€ or tokens, for either return or retain..



Laminate door colour options

Create a storage solution that closely matches your branding or blends subtly into the background with a range of coloured door options to choose from.

Choose from our Standard range or specify a  laminate to match your architectural design.

Solid grade laminate with fire classification available at additional cost.

Please ask us for further information on fire classifications and applications.



ZENBOX and ZENBOXULTRA stock 12mm SGL SOLID COLOUR finishes - aluminium body

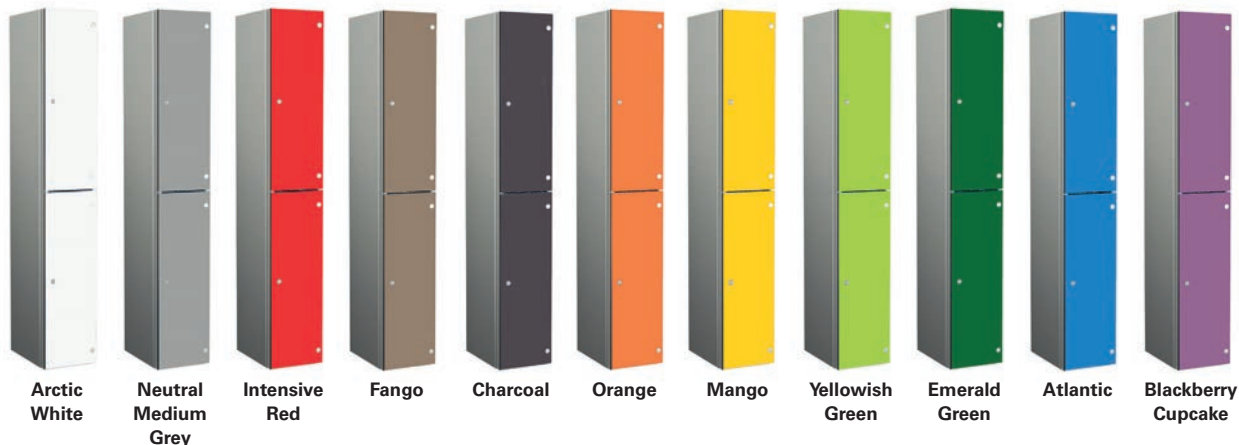

ZENBOX and ZENBOXULTRA additional 12mm SGL SOLID COLOUR finishes, available on an extended lead time.

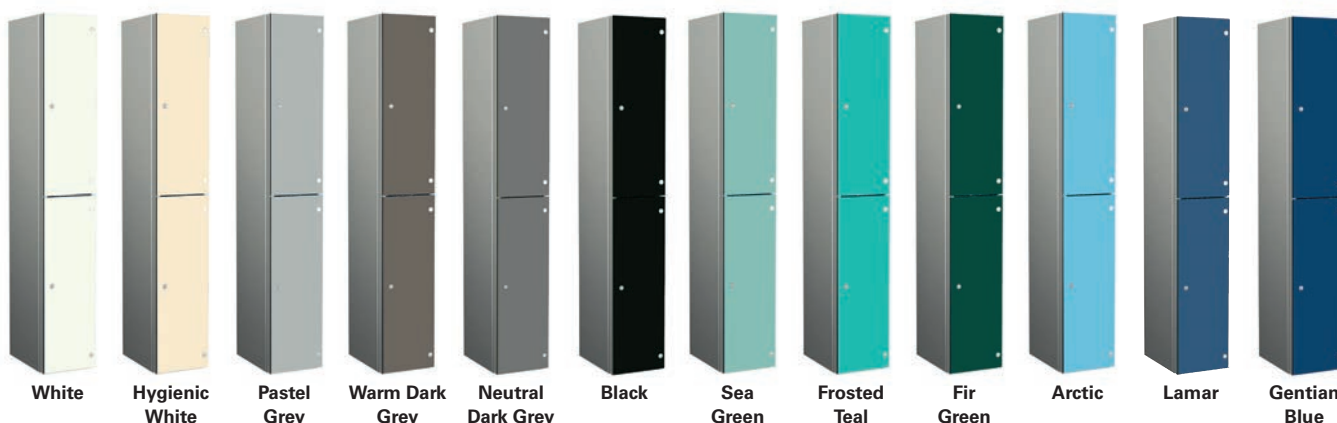

ZENBOX and ZENBOXULTRA stock 12mm SGL TEXTURED finishes



ZENBOX and ZENBOXULTRA additional 12mm SGL TEXTURED finishes, available on an extended lead time.



Please note that due to printing restrictions colours represented may differ from original product. We recommend you request a colour swatch before ordering.

Accessories

Aluminium Locker Support Stands

Locker support stands raise lockers off the floor, reducing impact damage and making cleaning easier. Manufactured from 25mm square aluminium section they are ideal for wet environments.

All units come complete with adjustable feet to aid levelling on uneven floors.

Optional 10mm solid grade laminate (SGL) plinth available to match or contrast with the locker doors.

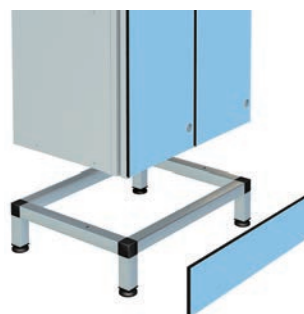
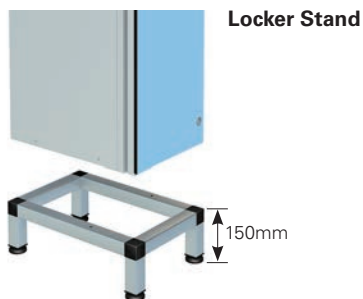

Locker stand with plinth

Locker stand plinths are manufactured using 10mm Solid grade laminate (SGL) to match or contrast with the locker doors.

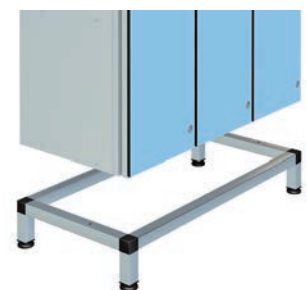

Aluminium Seats and Stands

10mm solid grade laminate seat (SGL) and 45mm aluminium framework form a bench seat in front of the locker, allowing full access to the locker.

Seat can match or contrast with the locker door or with an optional SGL plinth.

All units come complete with adjustable feet to aid levelling on uneven floors.

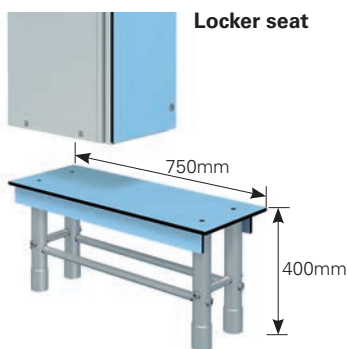

Locker seat plinths

Locker seat plinths are manufactured using 10mm solid grade laminate (SGL) to match or contrast with the locker doors.



Sloping Top

Sloping tops are a good way of preventing litter, bags and other items being left on top of the lockers. The sloping top also makes cleaning easier. Sloping tops are essential in hygiene – sensitive applications such as the NHS or food preparation. Sloping tops add 150mm height to the locker.



Numbering System

Optional inset number plates are available. Discs are recessed into the door. Request when placing order.



Probe

01244 940792

| info@probe-lockers.ltd.uk

| www.probe-lockers.ltd.uk

TimberBox Lockers

MDF timber effect door steel lockers



Probe

TimberBox lockers



Sloping Tops

Available as option. See [page 4](#).



Numbering system

Optional number plates will be recessed into door if ordered with lockers.



Soft close hinges

Hinges open through 90° for ease of access and are damped for soft closure.



Strength and style

The doors and end panels comprise of a sturdy 18mm MFD core laminate with 2mm PVC edging.

Range of lock options

A range of quality engineered locks available. See [page 4](#).

End panels to match the doors

End panels can be manufactured to add on to the end of locker runs or to the side of each individual locker if required.

Panels available to match flat or sloping top lockers.

Still a big favourite with the leisure industry; wooden finish MFC doors always look smart and sleek in any environment. Probe offer five durable timber effect door finishes, on a standard steel body, in 1,2,3,4 & 6 compartment lockers.

- Available in a range of five MDF timber finishes.
- Choose from Silver Grey, White or Black carcass colours.
- Plant-on doors cover the front face of the locker body, creating a aesthetically pleasing finish.
- Colour matched end panels are available to clad locker run ends.
- Optional sloping tops improve hygiene and housekeeping.
- Support frames, stands and bench also available.



Probe Steel Products are fire tested and approved in line with European Standard - EN 13501-1: 2007 +A1: 2009



All painted components are protected with a powder coating which incorporates ActiveCoat anti-bacterial technology.

ActiveCoat has been tested by an Internationally recognised microbiological testing laboratory for antibacterial performance, against the most widely encountered and problematic organisms including the MRSA Super bug and E-coli. These micro-organisms suffered a 99.9% reduction in population.



Important note regarding locker installations

Wherever possible lockers should be secured to ensure stability. Single lockers should ideally be fixed back to a wall. Runs of lockers should be fixed together side-to-side and either fixed back to a wall or fixed back-to-back to another run of lockers.

The range



Single compartment
Lugano Oak Door
Fixed top shelf with double coat hook.



Two compartment
Beech Doors
Double coat hook per compartment.



Three compartment
Cannole Oak Doors



Four compartment
Walnut Doors



Six compartment
Maple Doors

Height - 1800mm*	
Width mm	Depth mm
300	318
300	468
380	468
450	468

* Height increases with sloping top. See [page 4](#).

Locker accessories



Sloping top height	
Locker depth	Additional height
318	125
468	187

Sloping tops are essential in hygiene sensitive locations (such as hospitals and the food industry). The slope prevents items and litter being left on locker tops and makes cleaning easier. Sloping Tops have an upward slope from front to back.



Lockers are often used in areas where floors need frequent cleaning. Locker stands provide maximum floor access raising lockers 150mm off the floor. Matched plinths are available to complete the look.



Two hardwood slats and metal framework form a bench seat in front of the locker, allowing full access to the locker. Units are 400mm high and come complete with adjustable feet.



Panels can be added onto the end of the locker runs to totally envelop the lockers in your chosen finish

Also available;

- Hanging rail
- Captive coat hanger



Lock options

*Included in locker price. Request lock type at time of ordering.



Type A – Probe cam lock*

Even the standard lock has a micro sprung 10 disc lock featuring a massive 2000 serial combinations - all exclusive to Probe. Two keys are included with each standard lock.



Type B – Hasp & staple*

Attractive design allowing easy use of padlock. Transfers responsibility for locking to the user. The user requires a padlock (not supplied) with a shackle diameter of 7mm.



Type P – Re-programmable combination lock User Re-programmable

An effective 4 digit code combination lock with 10,000 possible combinations, making losing keys a thing of the past. Suitable for multi user applications. Master override key sold separately.



Type L – Digital combination lock 40,000 combinations

Simple to program battery operated lock which can last up to 50,000 operations before needing changing. Emergency access using service key. Single user supplied as standard but multi-user option is available (specify when ordering)

Locker colours & codes

MDF TIMBERBOX door finishes



Carcass colours



Please note that due to printing restrictions colours represented may differ from original product. We recommend you request a colour swatch before ordering.

Locker codes

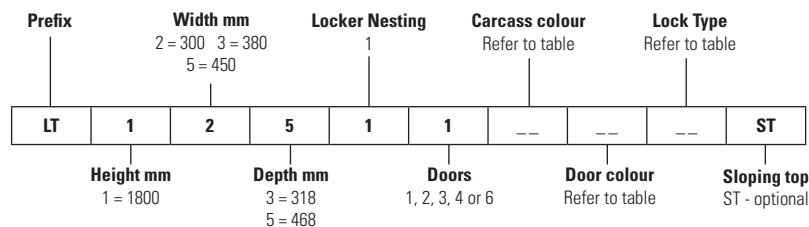

Example locker codes

LT13514QDXD11 TimberBox locker, 1800(H),380(W),468(D), 4 door, nest 1, silver grey carcass, Walnut doors, hasp & staple padlock fitting lock

LT13514QDXD11ST TimberBox locker, 1800(H),380(W),468(D), 4 door, nest 1, silver grey carcass, Walnut doors, hasp & staple padlock fitting lock, sloping top

Lock Codes

Code	Type	Description
00	Type A	Cam lock / deadlock
11	Type B	Hasp & Staple
81	Type H	Coin return
68V	Type L	Digital combination - vertical orientation
68H	Type L	Digital combination - horizontal orientation
6P	Type P	Reprogrammable combination

Carcass colour

Code	Colour
XD	Silver / Grey
SK	Black
NG	White

Door colour

Code	Colour
QD	Walnut
IQ	Beech
JL	Maple
MX	Lugano Oak
NH	Cannola Oak

Probe

01244 940 792 | info@probe-lockers.ltd.uk

| www.probe-lockers.ltd.uk

The information contained in this leaflet was accepted as correct at the date of publication. However, we reserve the right to make any necessary changes, in line with product development and trading conditions. Although all reasonable care has been taken to make it as complete and accurate as possible, no liability can be accepted for any inaccuracies or omissions. E+OE.

BuzzBox Lockers

MFC door steel lockers



Probe

BuzzBox lockers



Optional sloping top available.
See **page 4**.



Range of lock options

A range of quality engineered locks available.
See **page 4**.



Soft close hinges

Hinges open through 90° for ease of access and are damped for soft closure.



Numbering system

Optional number plates will be recessed into door if ordered with lockers.

Strength and style

The doors and end panels comprise of a sturdy FSC certified 18mm MFC core laminated in a choice of five contemporary colours.

End panels to match the doors

End panels can be manufactured to add on to the end of locker runs or to the side of each individual locker if required.

Panels available to match flat or sloping top lockers.

These sophisticated lockers add a new level of style to contemporary spaces, from office to school, retail to leisure. We offer these beautiful and durable satin finish doors fitted to our sturdy steel body lockers, in 1,2,3,4 and 6 compartment options.

- Available in a range of five door colours.
- Choose from Silver Grey, White or Black carcass colours.
- Plant-on doors cover the front face of the locker body, creating a wall of colour.
- Colour matched end panels are available to complete the aesthetics.
- Optional sloping tops improve hygiene and housekeeping.
- Support frames, stands and bench also available.



Probe Steel Products are fire tested and approved in line with European Standard - EN 13501-1: 2007 +A1: 2009



All painted components are protected with a powder coating which incorporates ActiveCoat anti-bacterial technology.

ActiveCoat has been tested by an Internationally recognised microbiological testing laboratory for antibacterial performance, against the most widely encountered and problematic organisms including the MRSA Super bug and E-coli. These micro-organisms suffered a 99.9% reduction in population.



Important note regarding locker installations

Wherever possible lockers should be secured to ensure stability. Single lockers should ideally be fixed back to a wall. Runs of lockers should be fixed together side-to-side and either fixed back to a wall or fixed back-to-back to another run of lockers.

The range

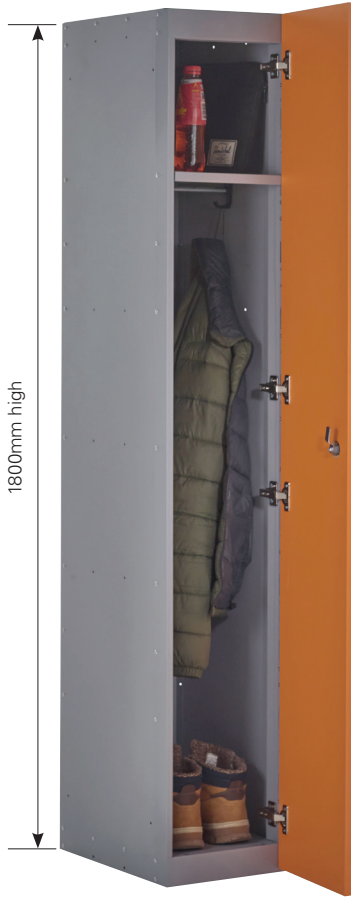

Single compartment
Goldfish Orange Door
Fixed top shelf with
double coat hook.



Two compartment
Snow White Doors
Double coat hook
per compartment.



Three compartment
Lemon Doors



Four compartment
Black Doors



Six compartment
Cashmere Doors

Height - 1800mm*	
Width mm	Depth mm
300	318
300	468
380	468
450	468

* Height increases with sloping top. See page 4.

Locker accessories & lock options



Sloping top height	
Locker depth	Additional height
318	125
468	187

Sloping tops are essential in hygiene sensitive locations (such as hospitals and the food industry). The slope prevents items and litter being left on locker tops and makes cleaning easier. Sloping Tops have an upward slope from front to back which will add 150mm to the height to your locker.



Lockers are often used in areas where floors need frequent cleaning.

Locker stands provide maximum floor access raising lockers 150mm off the floor.

Matched plinths are available to complete the look.



Two hardwood slats and metal framework form a bench seat in front of the locker, allowing full access to the locker.

Units are 400mm high and come complete with adjustable feet.



Panels can be added onto the end of the locker runs to totally envelop the lockers in your chosen finish

Also available;

- Hanging rail
- Captive coat hanger



Lock options

*Included in locker price. Request lock type at time of ordering.



Type A – Probe cam lock*

Even the standard lock has a micro sprung 10 disc lock featuring a massive 2000 serial combinations- all exclusive to Probe. Two keys are included with each standard lock.



Type B – Hasp & staple*

Attractive design allowing easy use of padlock. Transfers responsibility for locking to the user. The user requires a padlock (not supplied) with a shackle diameter of 7mm.



Type P – Re-programmable combination lock

User Re-programmable

An effective 4 digit code combination lock with 10,000 possible combinations, making losing keys a thing of the past.

Suitable for multi user applications. Master override key sold separately.



Type L – Digital combination lock 40,000 combinations

Simple to program battery operated lock which can last up to 50,000 operations before needing changing. Emergency access using service key. Single user supplied as standard but multi-user option is available (specify when ordering)

Locker colours & codes

BUZZBOX MFC Satin finish

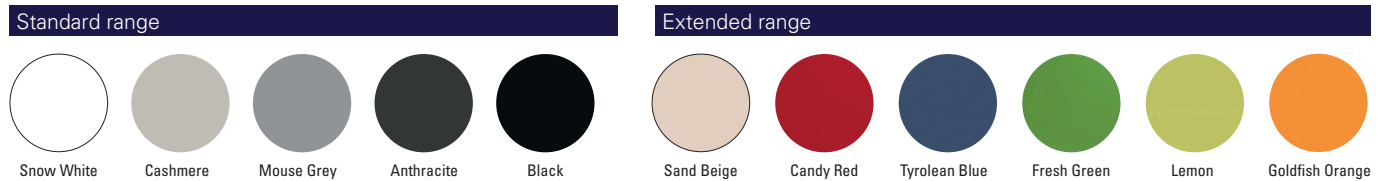

Carcass colours



Please note that due to printing restrictions colours represented may differ from original product. We recommend you request a colour swatch before ordering.

Locker codes

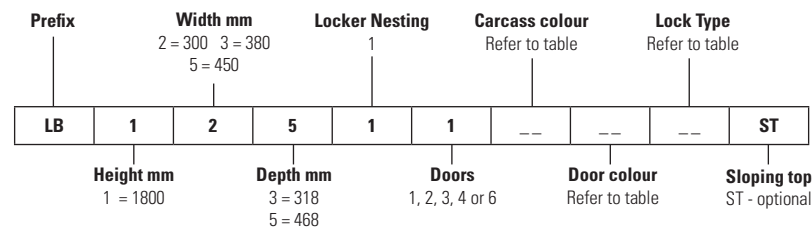

Example locker codes

LB13514EFXD11 TimberBox locker, 1800(H),380(W),468(D), 4 door, nest 1, silver grey carcass, Anthracite doors, hasp & staple padlock fitting lock

LB13514EFXD11ST TimberBox locker, 1800(H),380(W),468(D), 4 door, nest 1, silver grey carcass, Anthracite doors, hasp & staple padlock fitting lock, sloping top

Lock Codes

Code	Type	Description
00	Type A	Cam lock / deadlock
11	Type B	Hasp & Staple
81	Type H	Coin return
68V	Type L	Digital combination - vertical orientation
68H	Type L	Digital combination - horizontal orientation
6P	Type P	Reprogrammable combination

Carcass colour

Code	Colour
XD	Silver / Grey
SK	Black
NG	White

Door colour

Code	Colour
AH	Snow White
BV	Cashmere
DI	Mouse Grey
EF	Anthracite
GO	Black
AW	Sand Beige
IK	Candy Red
EN	Tyrolean Blue
JP	Fresh Green
PV	Lemon
SU	Goldfish Orange

Probe

01244 940792 | info@probe-lockers.ltd.uk | www.probe-lockets.ltd.uk

The information contained in this leaflet was accepted as correct at the date of publication. However, we reserve the right to make any necessary changes, in line with product development and trading conditions. Although all reasonable care has been taken to make it as complete and accurate as possible, no liability can be accepted for any inaccuracies or omissions. E+OE.

ShockBox Lockers

Dry area laminate door lockers



Probe

ShockBox lockers

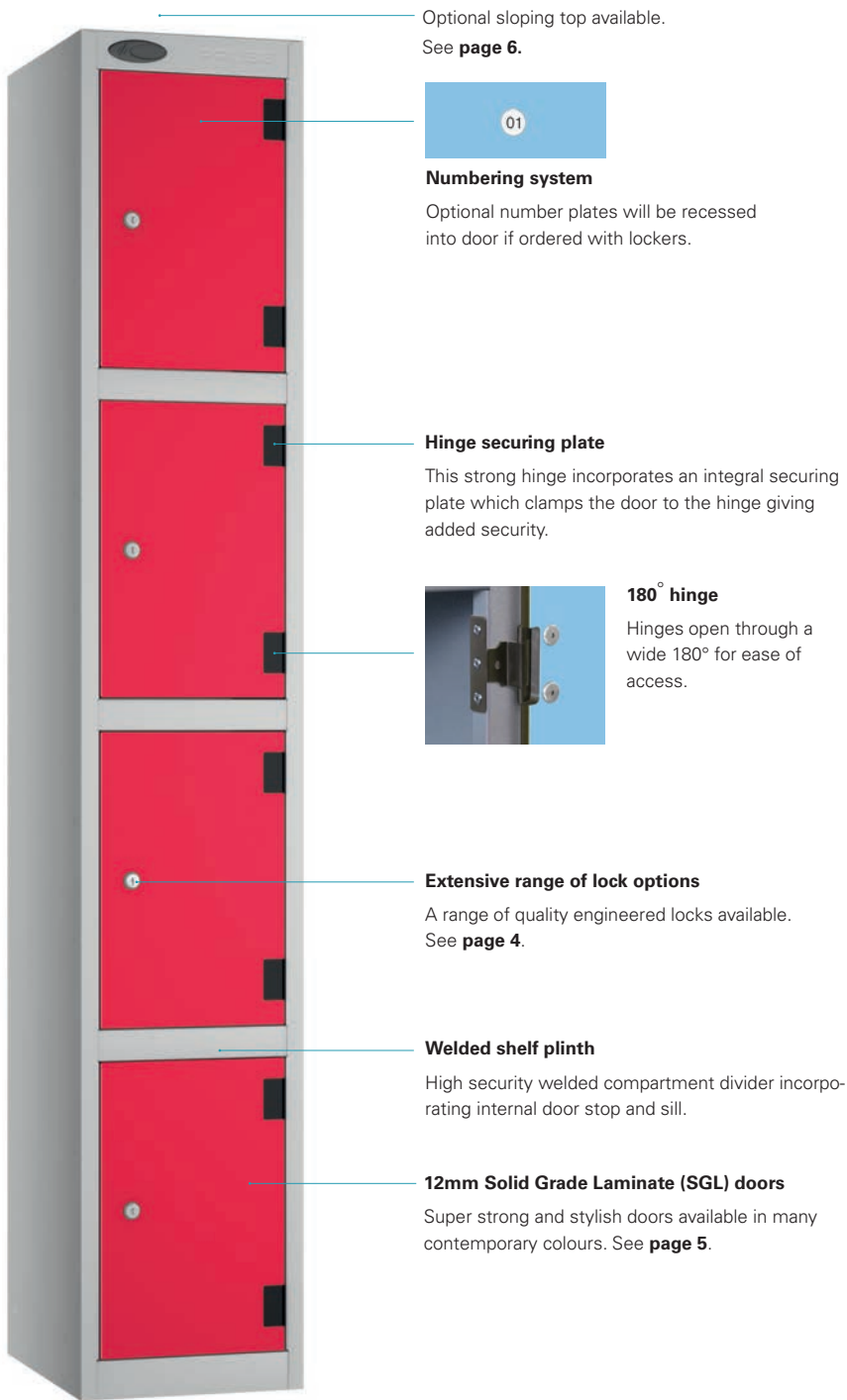

Optional sloping top available. See **page 6**.



Numbering system

Optional number plates will be recessed into door if ordered with lockers.

Hinge securing plate

This strong hinge incorporates an integral securing plate which clamps the door to the hinge giving added security.



180° hinge

Hinges open through a wide 180° for ease of access.

Extensive range of lock options

A range of quality engineered locks available. See **page 4**.

Welded shelf plinth

High security welded compartment divider incorporating internal door stop and sill.

12mm Solid Grade Laminate (SGL) doors

Super strong and stylish doors available in many contemporary colours. See **page 5**.

With durable laminate doors that are less likely to scratch, dent or be damaged, **SHOCKBOX** is suited to dry areas that receive high volumes of traffic and use.

■ Available in a range of colours.



Inset doors

Provide a visual contrast between the door finish and the locker frame.

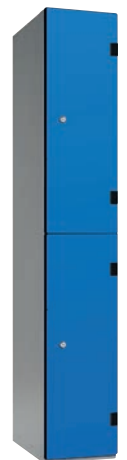

Overlay doors

Cover the front face of the locker body, creating a wall of colour.



ACTIVECOAT

All painted components are protected with a powder coating which incorporates ActiveCoat anti-bacterial technology.

ActiveCoat has been tested by an Internationally recognised microbiological testing laboratory for antibacterial performance, against the most widely encountered and problematic organisms including the MRSA Super bug and E-coli. These micro-organisms suffered a 99.9% reduction in population.



Laminate doors are available in a vast range of contemporary colours from leading manufacturer Fundermax. Choose from our Standard Range or specify a laminate to match your architectural design.



Important note regarding locker installations

Wherever possible lockers should be secured to ensure stability. Single lockers should ideally be fixed back to a wall. Runs of lockers should be fixed together side-to-side and either fixed back to a wall or fixed back-to-back to another run of lockers.

The range



Inset doors

Height - 1800mm*	
Width mm	Depth mm
300	380
300	450
380	380
380	450

Overlay doors

Height - 1800mm*	
Width mm	Depth mm
300	392
300	462
380	392
380	462

* Height rises with sloping top

End panels to match the doors

End panels can be manufactured to add on to the end of locker runs or to the side of each individual locker if required.



Dry Area lock options

*Included in locker price. Request lock type at time of ordering.



Type A – Probe cam lock*

Even the standard lock has a micro sprung 10 disc lock featuring a massive 2000 serial combinations- all exclusive to Probe. Two keys are included with each standard lock.



Type B – Hasp & staple*

Attractive design allowing easy use of padlock. Transfers responsibility for locking to the user. The user requires a padlock (not supplied) with a shackle diameter of 7mm.



Type P – Re-programmable combination lock

User Re-programmable

An effective 4 digit code combination lock with 10,000 possible combinations, making losing keys a thing of the past.

NOT suitable for multi user applications. Master override key sold separately.



Type SPU - Public Type SPR - Private

Public multi-user auto scramble combination lock

Automatically scrambles to 0000 when opened. Has 999 highly secure combinations available - no batteries needed. It has a metal matte black shell and has a master key override (supplied separately) for code finding and lock resetting.



Type L – Digital combination lock 40,000 combinations

Simple to program battery operated lock which can last up to 50,000 operations before needing changing. Emergency access using service key. Single user supplied as standard but multi-user option is available (specify when ordering)

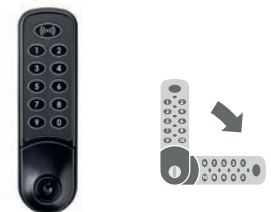

Type N – Nimbus RFID lock

The Nimbus RFID digital lock provides contactless locking and is compatible with RFID standards and incorporates a membrane touchpad for ease of programming. The keypad can also be used to override the lock when required.



Type H (£1) – Dual coin/token return/retain

These locks are available with coin denominations £/€ or tokens, for either return or retain.

Laminate door colour options

Create a storage solution that closely matches your branding or blends subtly into the background with a range of coloured door options to choose from.

Choose from our Standard range or specify a laminate to match your architectural design.

Solid grade laminate with fire classification available at additional cost.

Please ask us for further information on fire classifications and applications.



SHOCKBOX stock 12mm SGL SOLID COLOUR finishes - Choice of Silver Grey, White or Black painted bodies

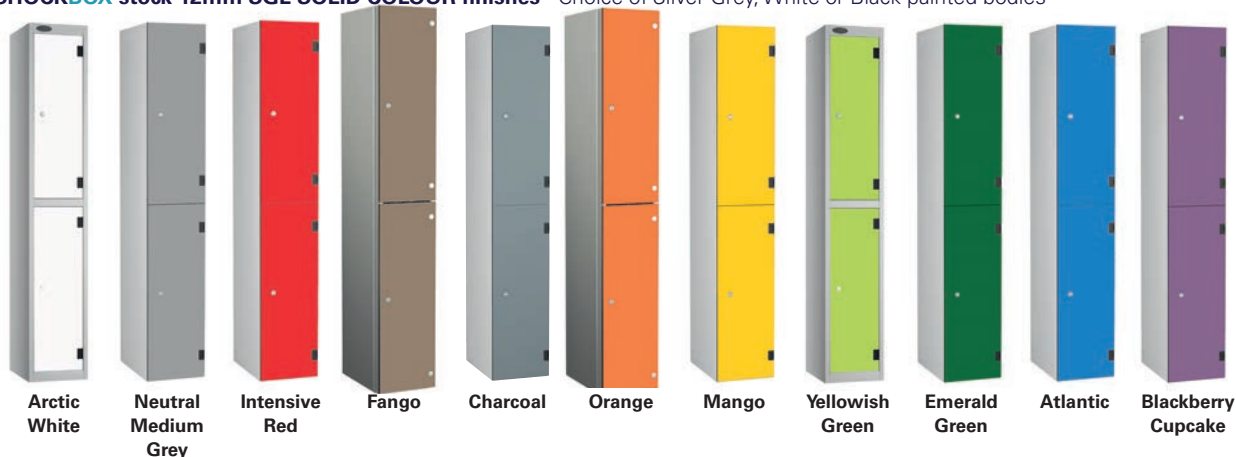

SHOCKBOX additional door colour 12mm SGL SOLID COLOUR finishes, available on an extended lead time.

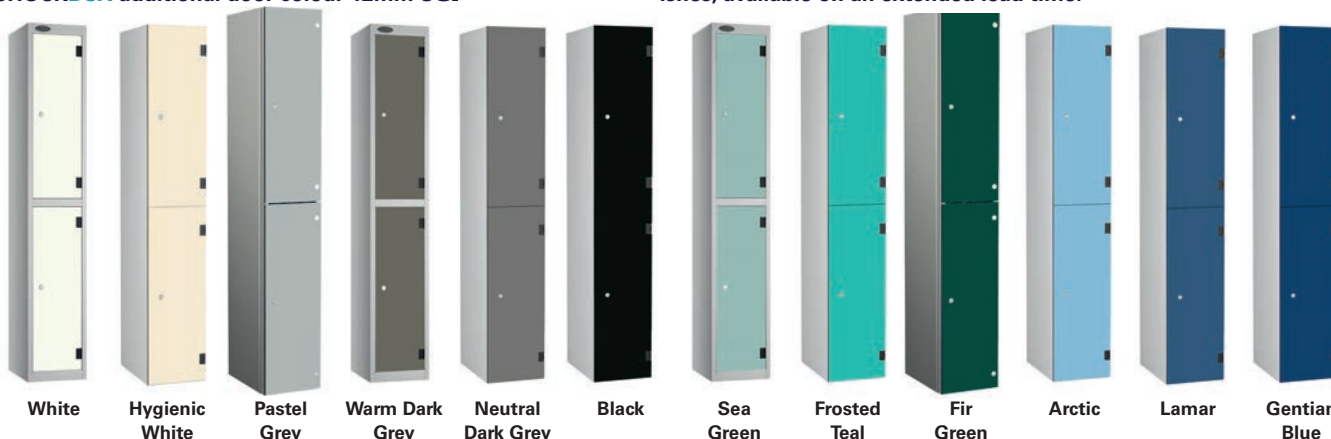

SHOCKBOX stock 12mm SGL TEXTURED finishes - Choice of Silver Grey, White or Black painted bodies



SHOCKBOX additional 12mm SGL TEXTURED finishes, available on an extended lead time.



Please note that due to printing restrictions colours represented may differ from original product. We recommend you request a colour swatch before ordering.

Accessories and nesting

Accessories



Sloping top height	
Locker depth	Additional height
380	158
450	187

Sloping tops are essential in hygiene sensitive locations (such as hospitals and the food industry). The slope prevents items and litter being left on locker tops and makes cleaning easier. Sloping Tops have a 22° upward slope from front to back which will add height to your locker. This varies according to the locker depth.



Lockers are often used in areas where floors need frequent cleaning. Locker stands provide maximum floor access raising lockers 150mm off the floor.

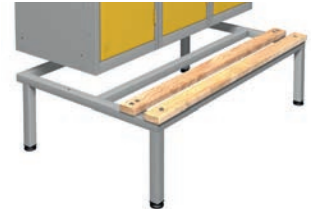

Two hardwood slats and metal framework form a bench seat in front of the locker, allowing full access to the locker. Units are 400mm high and come complete with adjustable feet.

Also available;

- Double coat hook
- Hanging rail
- Captive coat hanger



Probe

01244 940792 | info@probe-lockers.ltd.uk

| www.probe-lockers.ltd.uk

The information contained in this leaflet was accepted as correct at the date of publication. However, we reserve the right to make any necessary changes, in line with product development and trading conditions. Although all reasonable care has been taken to make it as complete and accurate as possible, no liability can be accepted for any inaccuracies or omissions. E+OE.